



# TECHNICAL GUIDE

## V-SHORE

FALSEWORK & SHORING

Any safety provisions as directed by the appropriate governing agencies must be observed when using our products. The pictures in this document are snapshots of situations at different stages of assembly, and therefore are not complete images. For the purpose of safety, they should not be deemed as definitive.

The loads featured in this document, related to the parts of the product, are approximate.

The company reserves the right to introduce any modifications deemed necessary for the technical development of the product.

ALL RIGHTS RESERVED.

Neither all nor part of this document may be reproduced or transmitted in any way by any electronic or mechanical procedure, including photocopy, magnetic recording or any other form of information storage or retrieval system without the written permission.

©COPYRIGHT BY ACROW2023

DOCUMENT NO: ACROWVSHORE\_FEB2024\_ISSUE\_B



## Technical Manual Release Notes

This page is intended to record all changes to the **V-SHORE** technical manual pages.

Changes or additions to this manual will be itemised with a brief description and date when the amendments were made.

ISSUE	DATE	Amendment Description
A	SEPT 2023	First Release
B	FEB 2024	Second Release

## Contents

<b>1. TECHNICAL SPECIFICATIONS</b>	<b>1.1</b>
System Description	1.1
Purpose of the Document	1.1
Safety Information	1.1
Safety Information Cont.	1.2
Important Information	1.2
Disclaimer	1.2
Applicable Codes and Standards	1.2
<b>2. GENERAL PRODUCT INFORMATION</b>	<b>2.1</b>
Framing	2.2
Components Misc.	2.3
<b>3. WORKING LOAD LIMITS (WLL)</b>	<b>3.1</b>
Notes and Conditions	3.2
2100 Frame Working Load Capacity	3.2
900 -1800 Frame Working Load Capacity	3.3
Maximum Working Load Orientation: Beams Perpendicular to Frame	3.3
Maximum Working Load Orientation: Beams Parallel to Frame	3.4
<b>4. SYSTEM DETAILS</b>	<b>4.1</b>
Usage Recommendations	4.2
Frame Sizing	4.3
X-Bracing Sizing	4.4
<b>5. ASSEMBLY DETAILS</b>	<b>5.1</b>
Typical Details - Parallel to Frame	5.2
Typical Details - Perpendicular to Frame	5.3
<b>6. TRANSPORT &amp; HANDLING</b>	<b>6.1</b>
Frames	6.2
Adjustable Bases	6.3
<b>7. MAINTENANCE &amp; INSPECTION</b>	<b>7.1</b>
Frame Identification System - X Brace Codes	7.2
Bracing	7.3
Cross Bracing	7.4
Frame Connector	7.5
Adjustable U-Head - Solid or Tubular	7.6
Adjustable U-Head - Solid or Tubular	7.7
Base Plate	7.8

# 1. Technical Specifications

## System Description

**V-SHORE** is a medium duty shoring system comprising three major components – Frames, Braces & Jacks. Shoring can be adjusted to different heights, but is suitable for heights greater than 1 metre. It has a load carrying capacity of up to 35.1 kN per leg (W.L.L. in accordance with AS3610).

**V-SHORE** is the ideal, fast & practical system for civil engineering projects such as the construction of highway bridges or the laying of heavy slabs or beams. Due to its light weight construction & relatively few components, the V-Shore system maximizes productivity through easier handling, storage, erection & stripping.

Frames are light to handle. Lifting & transporting the shoring is made simple & a less labour-intensive task. V-Shore components are compactly designed requiring minimum storage space. The simplicity of the V-Shore system minimizes erection errors & maximizes erection speed.

**V-SHORE** design involves large grids & offers flexibility of support arrangements. These in turn make it easier for formworkers to increase or decrease frame grid positions relative to the concrete thickness to be supported.

All components are manufactured from quality steel & protected against corrosion with selected finishes that include Hot dipped in-line galvanising or Zinc plating.

## Purpose of the Document

The purpose of this document is to provide guidelines for design, safe handling, transport and installation of the **V-SHORE** system.

The document also outlines the various components of the system and it features illustrations, working load limits, typical assembly arrangements and safe transport and handling measures.

The information contained in this document is provided as a general guide only and does not replace the need for the design to be reviewed and checked by a qualified person in the field of temporary works design and installation, concrete, steel, building construction and services.

This material has been prepared in the context of relevant Australian Standards and the National Construction Code (NCC). Users should make themselves aware of any recent changes to these documents referred to therein and to local variations or requirements.

This document is NOT a substitute for site-specific Safe Operation Procedures. It is the Installation Contractors responsibility to prepare safe work method statements and observe and comply with site specific health and safety regulations, standards and policies.

Acrow Formwork and Scaffolding has dedicated engineering services available for project assistance. We can provide design support for clients to determine the best way to specify and document. Our technical experts can identify the most efficient temporary work design meeting project requirements, specifications and installation process.

Should the users require any further information or guidance, they are encouraged to contact their local Acrow branch.

## Safety Information

This safety information is to draw the user's attention to possible musculoskeletal disorders as a result of manual handling during assembly and dismantling of the **V-SHORE** system

It is recommended that users of the **V-SHORE** system employ and implement appropriate procedures and

## 1. Technical Specifications

### Safety Information Cont.

control measures to eliminate or control any risk of Musculoskeletal disorder/injury while handling.

Refer to the Code of Practice on manual handling published by local Workcover Authority or other approved and recognised guidelines for correct and appropriate manual handling procedures.

### Important Information

The erection and application instructions contained in this manual are the recommended methods to be used for **V-SHORE** products.

The technical function related instructions must be accurately followed to obtain the correct performance of the product. Any deviation from the recommended usage will require a separate design and/or verification by Acrow Engineering.

The safe use and application of the system must be in accordance with Australian Standard AS3610 Formwork for Concrete, Occupational Health & Safety regulations, approved industry codes of practice and relevant regulatory authority requirements.

The illustrations in these assembly configurations are minimum guidelines only.

The combined use of the **V-SHORE** system with equipment from other suppliers may entail performance issues and therefore requires a design check and/or verification by Acrow Engineering or a qualified experienced engineer.

Hazard Identification/Risk Assessments for the erection and dismantling of the system are available from Acrow branches. Site specific Hazard and Risk assessments may need to be generated for specific projects.

### Disclaimer

1. The photographs/illustrations shown within this manual are intended as expressing the diversity and possible applications of the product and as such must not be used as assembly instructions.
2. In line with Acrow commitment to continuous product development and improvement, the information contained in this manual may be changed without notice. Please confirm with Acrow Engineering for latest update.
3. While all reasonable effort has been taken to ensure the accuracy and adequacy of the information contained herein, Acrow, accepts no responsibility or liability for any loss or damage suffered by any person acting or refraining from action as a result of this information.

Should users require any expert assistance, they are encouraged to contact Acrow Engineering department.

### Applicable Codes and Standards

The structural design information and guide provided in this document are limited to the relevant codes nominated below. It does not include certification of any structures or works associated with a project.

ELEMENT	DESCRIPTION	CODE
LOADING	Structural Design Actions – General Principles	AS/NZS 1170.0-2002 (R2016)
	Structural Design Actions – Permanent, Imposed And Other Actions	AS/NZS 1170.1-2002
FORMWORK	Formwork for Concrete	AS 3610-1995
	Formwork for Concrete Part 1- Specifications	AS 3610.1-2018



## 2. GENERAL PRODUCT INFORMATION

## 2. General Product Information

### Framing

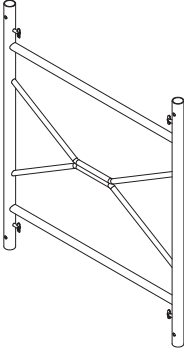
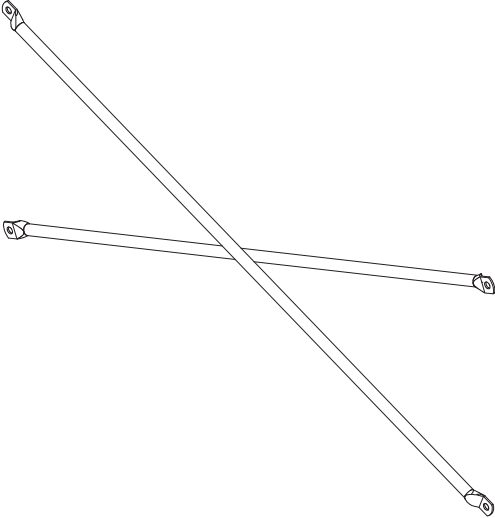
PRODUCT	DESCRIPTION	PRODUCT CODE	MASS (kg)
	<b>Framing</b> V-shore Frames come in five basic sizes. They can be connected to each other using Cross Braces to form a tower and vertically using Vertical Frame Connector to form the required height.		
	2140 x 1219mm (H x L)	FB21	32.0
	1829 x 1219mm (H x L)	FB18	29.1
	1524 x 1219mm (H x L)	FB15	26.0
	1219 x 1219mm (Straight Bar)	FB12	19.2
	914 x 1219mm (Straight Bar)	FB09	16.1
	<b>Tubular Cross Bracing</b> Braces allow frames to be used in towers. Large range available to suit varying latch pin spacing on frame legs. Made from Galtube Plus® for strength & durability		
	Frame X-Brace 3048 x 1524	XB105	8.4
	Frame X-Brace 2438 x 1524	XB85	7.2
	Frame X-Brace 2134 x 1524	XB75	6.6
	Frame X-Brace 1829 x 1524	XB65	6.0
	Frame X-Brace 1524 x 1524	XB55	5.5
	Frame X-Brace 3048 x 1220	XB104	8.1
	Frame X-Brace 2438 x 1220	XB84	6.9
	Frame X-Brace 2134 x 1220	XB74	6.2
	Frame X-Brace 1829 x 1220	XB64	5.6
	Frame X-Brace 1524 x 1220	XB54	4.9
	Frame X-Brace 1220 x 1220	XB44	4.4
	Frame X-Brace 3048 x 914	XB103	7.9
	Frame X-Brace 2438 x 914	XB83	6.5
	Frame X-Brace 2134 x 914	XB73	5.8
	Frame X-Brace 1829 x 914	XB63	5.1
	Frame X-Brace 1524 x 914	XB53	4.5
	Frame X-Brace 1220 x 914	XB43	3.8
	Frame X-Brace 2438 x 610	XB82	6.5
	Frame X-Brace 2134 x 610	XB72	5.7
	Frame X-Brace 1829 x 610	XB62	5.0
Frame X-Brace 1524 x 610	XB52	4.3	
Frame X-Brace 1220 x 610	XB42	3.6	



## 2. General Product Information

### Components Misc.

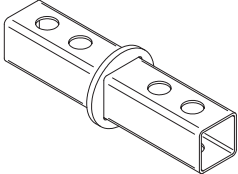
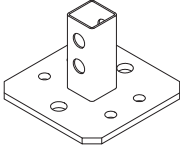
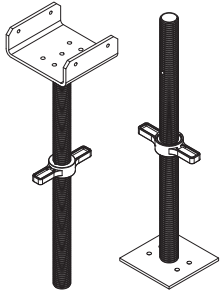
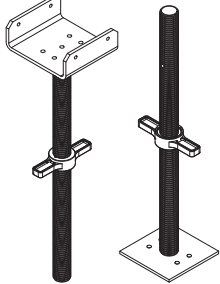
PRODUCT	DESCRIPTION	PRODUCT CODE	MASS (kg)
	<b>Frame Connector</b> Connector is used to allow support frames to be connected vertically. Connector features 4 holes to allow V-SHORE to be connected to similar frame systems. When crane handling is required, a connector pin is inserted through the frame legs & frame connector & locked in position with a spring clip.		
	Frame Connector	FC	0.5
	Connector Pin	EIP	0.2
	16mm Podger Pin	SMSCP16	0.19
	M16 Bolt	0241690	0.1
	M16 Nut	0241608	0.1
	<b>Base Plate</b> 150mmx150mm base plate used on flat surfaces, where jacks not required.		
	Base plate	BP	1.6
	<b>Tubular Adjustable Bases</b> Tubular jacks allow up to 600mm extension. U-Head measures 210mm clear between side plates.		
	Tubular Adjustable Base	ABTF	6.3
	Tubular Adjustable U-Head	AUHTF	10.3
	<b>Solid Adjustable Bases</b> Solid jacks allow up to 450mm extension & will also fit scaffold tube & system scaffold standards. Where solid jacks are used in V-SHORE frame legs ensure they are fitted with plastic spacer nuts to control eccentricity.		
	Adjustable Base	ABSFS	7.1
	Adjustable U-Head	AUHSFS	11.1

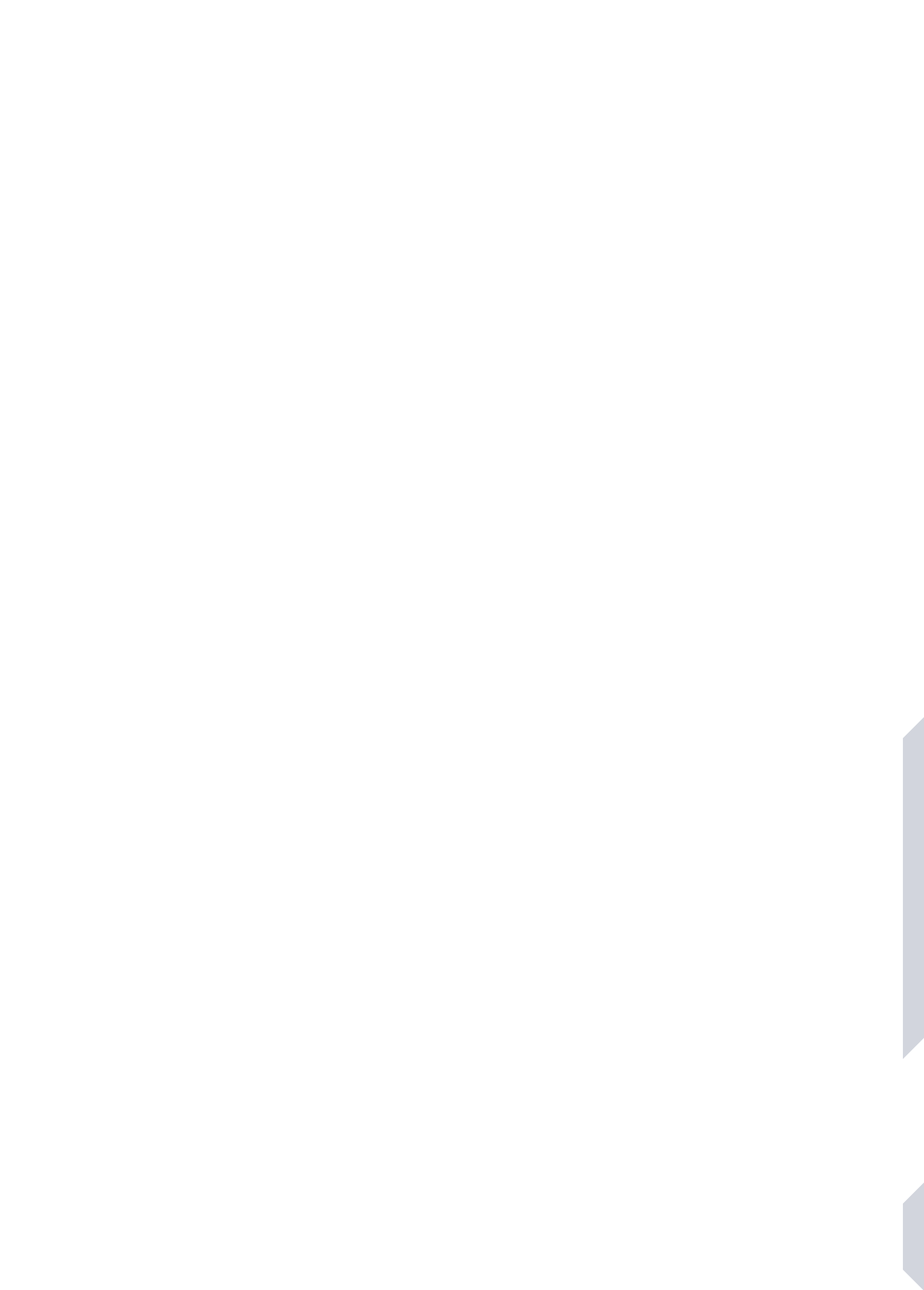

### 3. WORKING LOAD LIMITS (WLL)

### 3. Working Load Limits (WLL)

#### Notes and Conditions

- The Working Load Capacity shown in the tables and graphs is based on two frames high. Seek advice from Acrow's Engineering for stacking frames
- The cross braces must always be used to connect two frames together at specified and specific locations
- Plastic spacer nuts must be used with all solid jacks.
- Frame connectors must be used when connecting frames vertically together. 16mm pins with clips or M16 bolts & nuts must be used if there are any uplift forces in the falsework system or if the assembly requires crane handling.
- Eccentricity of the load action on the U-Head must not exceed 15mm on 914-1829mm and 10mm on 2140mm.
- Maximum out of plumb of any V-SHORE assembly shall not exceed height/200 or 40mm, whichever is less
- Additional bracings must be provided to resist horizontal forces
- Load charts are valid where V-SHORE frames are supported on suitable footing and foundation with adequate bearing capacity to resist imposed design leg loads. No allowance has been made for differential settlement
- Limit state conversion factor = 1.4

#### 2100 Frame Working Load Capacity

The maximum working load per leg for the V SHORE 2140 mm Frame are listed in the following table:

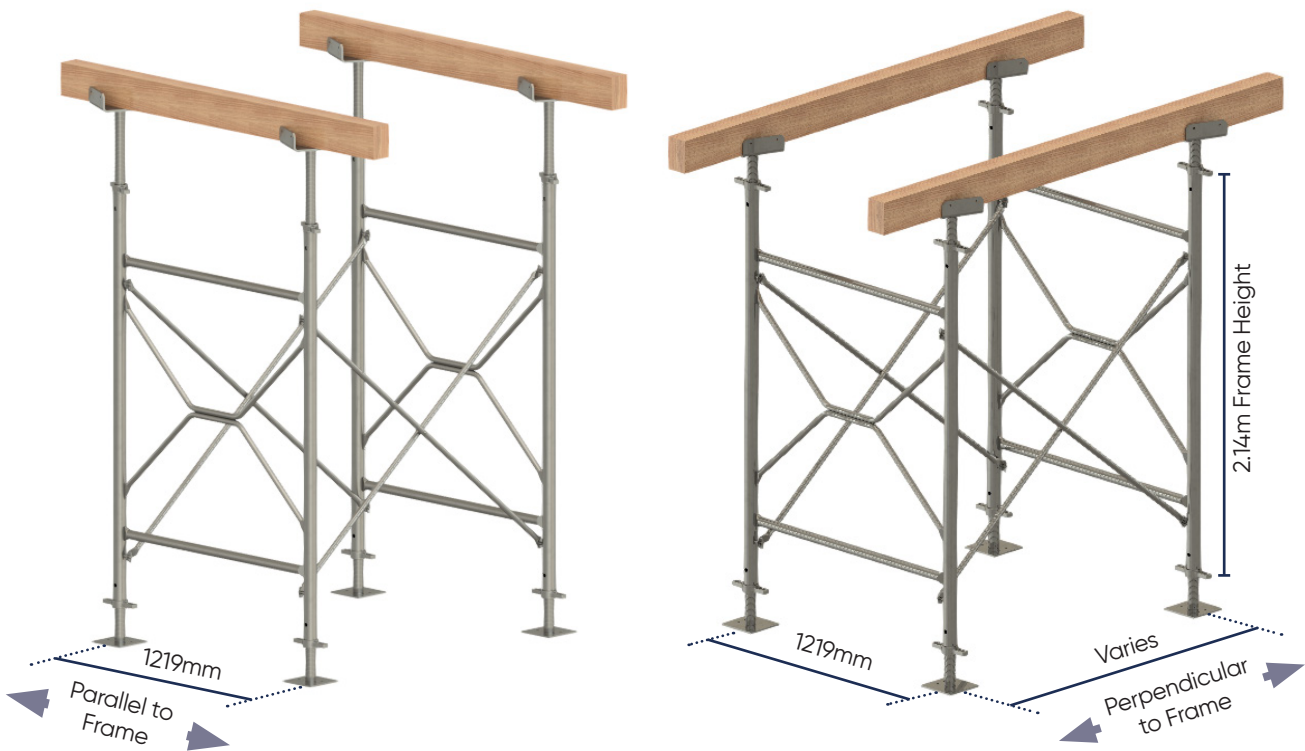

FRAME TOWER SETUP	ORIENTATION	WORKING LOAD CAPACITY (KN)	MAX JACK EXTENSION (mm)
V SHORE FRAME 2.14m HIGH	Parallel to Frames	20.7	550
	Perpendicular to Frames	21.9	550

**Note:**

- Eccentricity = 10mm

### 3. Working Load Limits (WLL)

#### 900 -1800 Frame Working Load Capacity

The maximum working loads per leg of the V SHORE 914 -1829 mm Frames are listed in the following tables and graphs

Maximum Working Load Orientation: Beams Perpendicular to Frame

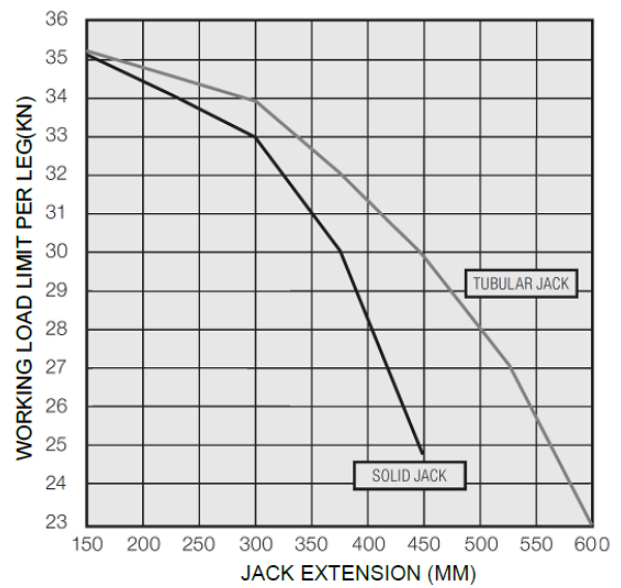
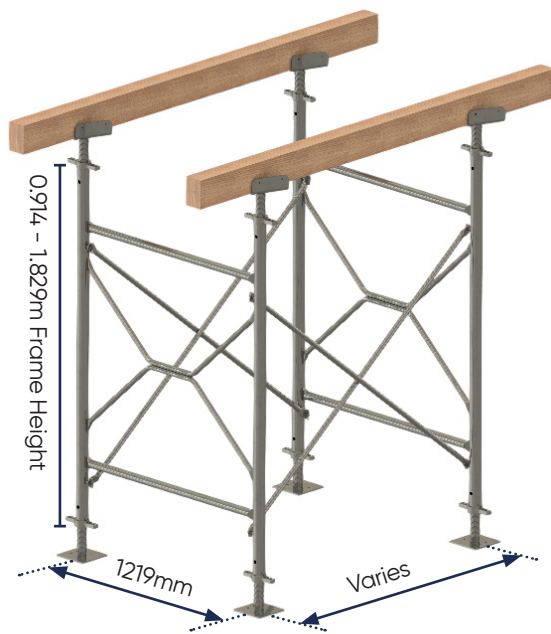

FRAME TOWER SETUP	ORIENTATION	WORKING LOAD CAPACITY (KN)		MAX JACK EXTENSION (mm)
		SOLID JACK	TUBULAR JACK	
<b>V SHORE FRAME 0.914 TO 1.829 m HIGH</b>	Perpendicular to Frames	35.1	35.1	150
		34.1	34.6	225
		33.0	33.9	300
		30.0	32.1	375
		24.7	29.9	450
		-	27.1	525
		-	23.0	600

**Note:**

- Eccentricity = 15mm

### 3. Working Load Limits (WLL)

Maximum Working Load Orientation: Beams Parallel to Frame

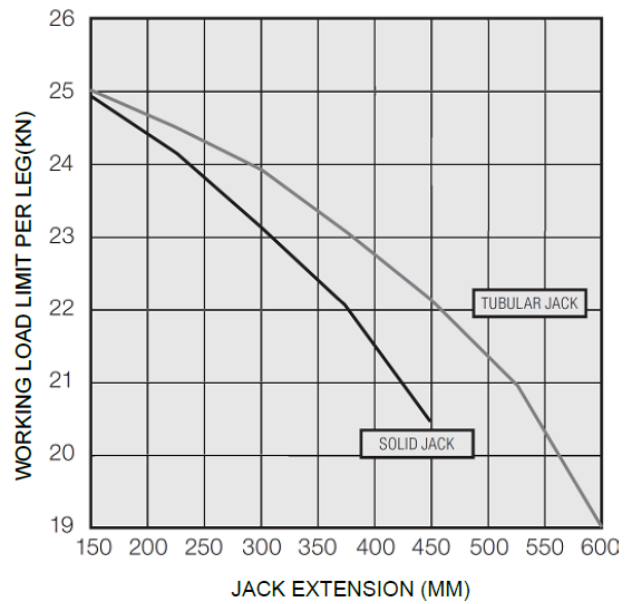
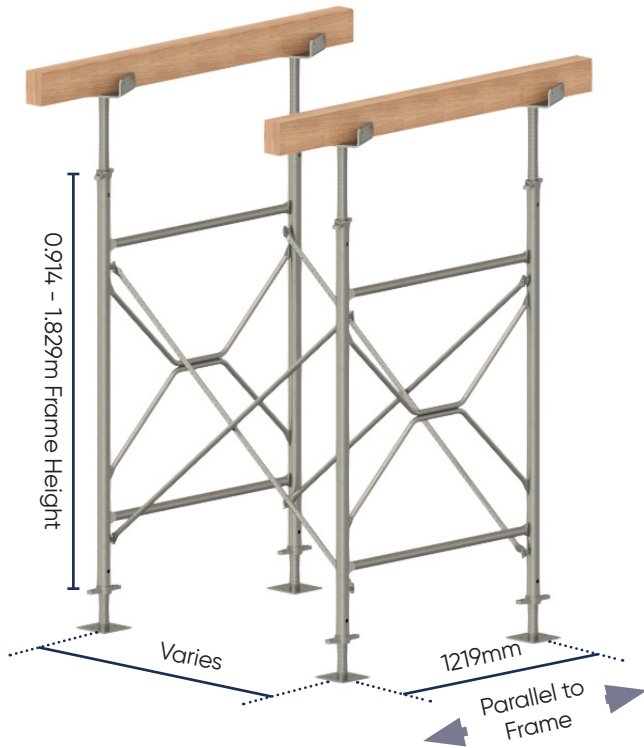

FRAME TOWER SETUP	ORIENTATION	WORKING LOAD CAPACITY (KN)		MAX JACK EXTENSION (mm)
		SOLID JACK	TUBULAR JACK	
<b>V SHORE FRAME</b> <b>0.914 TO 1.829 m HIGH</b>	Parallel to Frames	24.9	25.0	150
		24.2	24.5	225
		23.2	23.9	300
		22.1	23.1	375
		20.5	22.2	450
		-	20.9	525
		-	19.0	600

**Note:**

- Eccentricity = 15mm

## 4. SYSTEM DETAILS

## 4. System Details

### Usage Recommendations

1. V - Shore frames should not be used without either an adjustable base or base plate inserted in the bottom legs of the frame or tower.
2. Two cross braces must be used to connect two frames together at specified location at all times.
3. Plastic spacer nuts must be screwed onto the ends of Solid stem (36mm dia) adjustable bases or adjustable U - heads when inserted in the legs of V - Shore frames to minimise the clearance and restrain the end of the adjustable base or U-Head.
4. Sole plates with adequate stiffness and size to evenly transfer the applied loads to the foundation should be used under adjustable bases or base plates when bearing on foundations other than concrete.
5. Ensure that the adjustable base or the base plate is in full contact with their support (soleplate or concrete slab).
6. Falsework assembly must be supported on sound foundation material which prevents settlement and has adequate bearing capacity to support the applied leg loads.
7. Stability of the falsework and formwork assemblies must be maintained at all times and, if necessary, additional bracing and anchoring must be provided.
8. Do not use equipment in conjunction with the falsework which would apply dynamic forces unless they are allowed for in the falsework/formwork design.
9. Frame connectors must be used to connect frames vertically, connecting pins (16mm) must be inserted through the frame leg and the frame connector and locked with a spring clip if the tower is to be crane handled or there is any uplift forces in the falsework system.
10. Frames must be assembled the right way up, with the latch pins vertical under gravity. See drawing below:

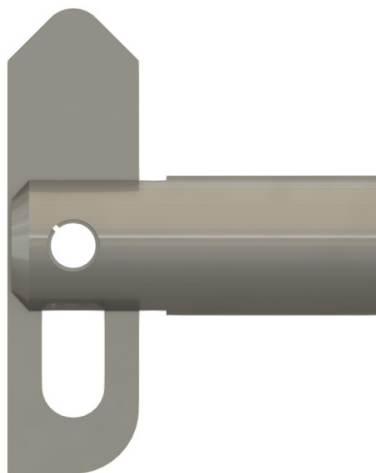



## 4. System Details

### Frame Sizing

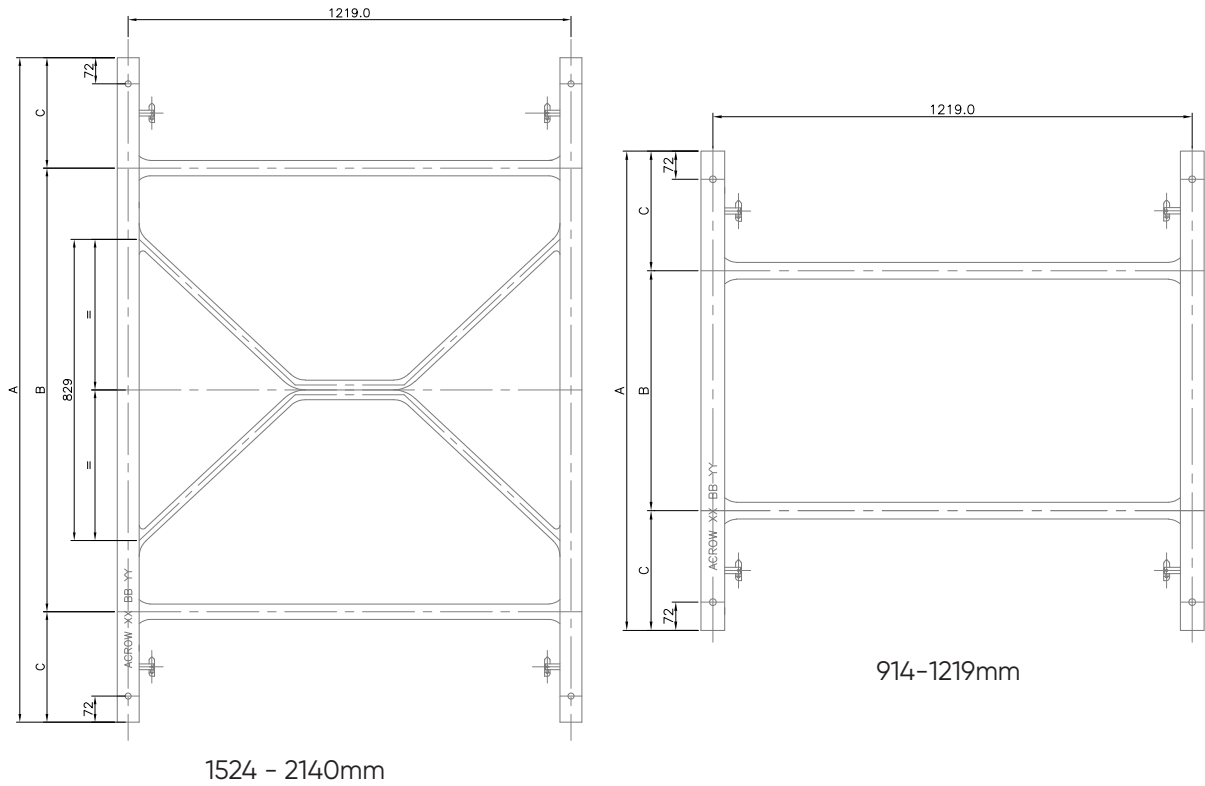

PRODUCT	A (mm)	B (mm)	C (mm)
2140 x 1219mm (H x L)	2134.0	1295.0	410.0 (top) 430.0 (bottom)
1829 x 1219mm (H x L)	1829.0	1221.0	304.0
1524 x 1219mm (H x L)	1524.0	1040.0	484.0
1219 x 1219mm (Straight Bar)	1219.0	610.0	304.5
914 x 1219mm (Straight Bar)	914.0	590.0	72 (top) 252 (bottom)

## 4. System Details

### X-Bracing Sizing

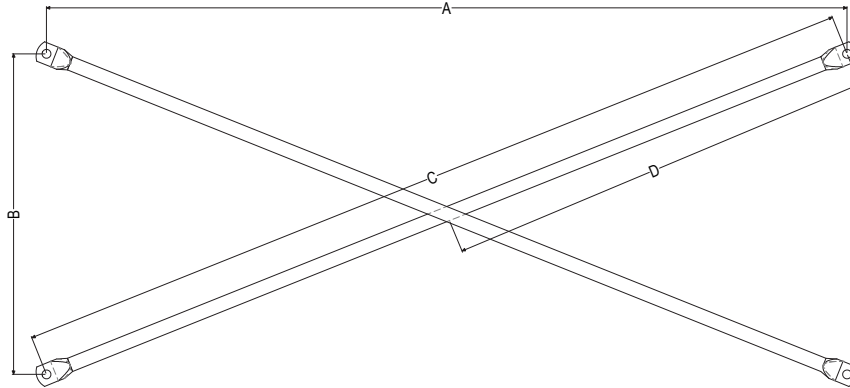

A: Spacing of Frames  
 B: Spacing of latch pins in Frame

CODE No	FRAME HEIGHT (mm)	BRACE SIZE (mm)		
		A	X	B
XB105	1828	3000	x	1524
XB85	1828	2438	x	1524
XB75	1828	2134	x	1524
XB65	1828	1829	x	1524
XB55	1828	1524	x	1524
XB104	1524 / 1828	3000	x	1220
XB84	1524 / 1828	2438	x	1220
XB74	1524 / 1828	2134	x	1220
XB64	1524 / 1828	1829	x	1220
XB54	1524 / 1828	1524	x	1220
XB44	1524 / 1828	1220	x	1220
XB103	1219	3000	x	914
XB83	1219	2438	x	914
XB73	1219	2134	x	914
XB63	1219	1829	x	914
XB53	1219	1524	x	914
XB43	1219	1220	x	914
XB82	1219	2438	x	610
XB72	914	2134	x	610
XB62	914	1829	x	610
XB52	914	1524	x	610
XB42	914	1220	x	610

## 5. ASSEMBLY DETAILS

## 5. Assembly Details

### Typical Details - Parallel to Frame

Main bearers Parallel to frame - weak direction

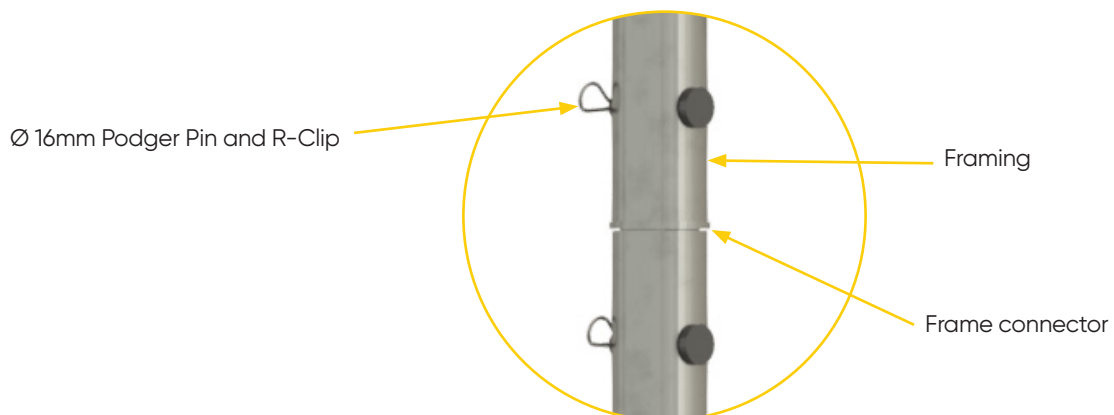
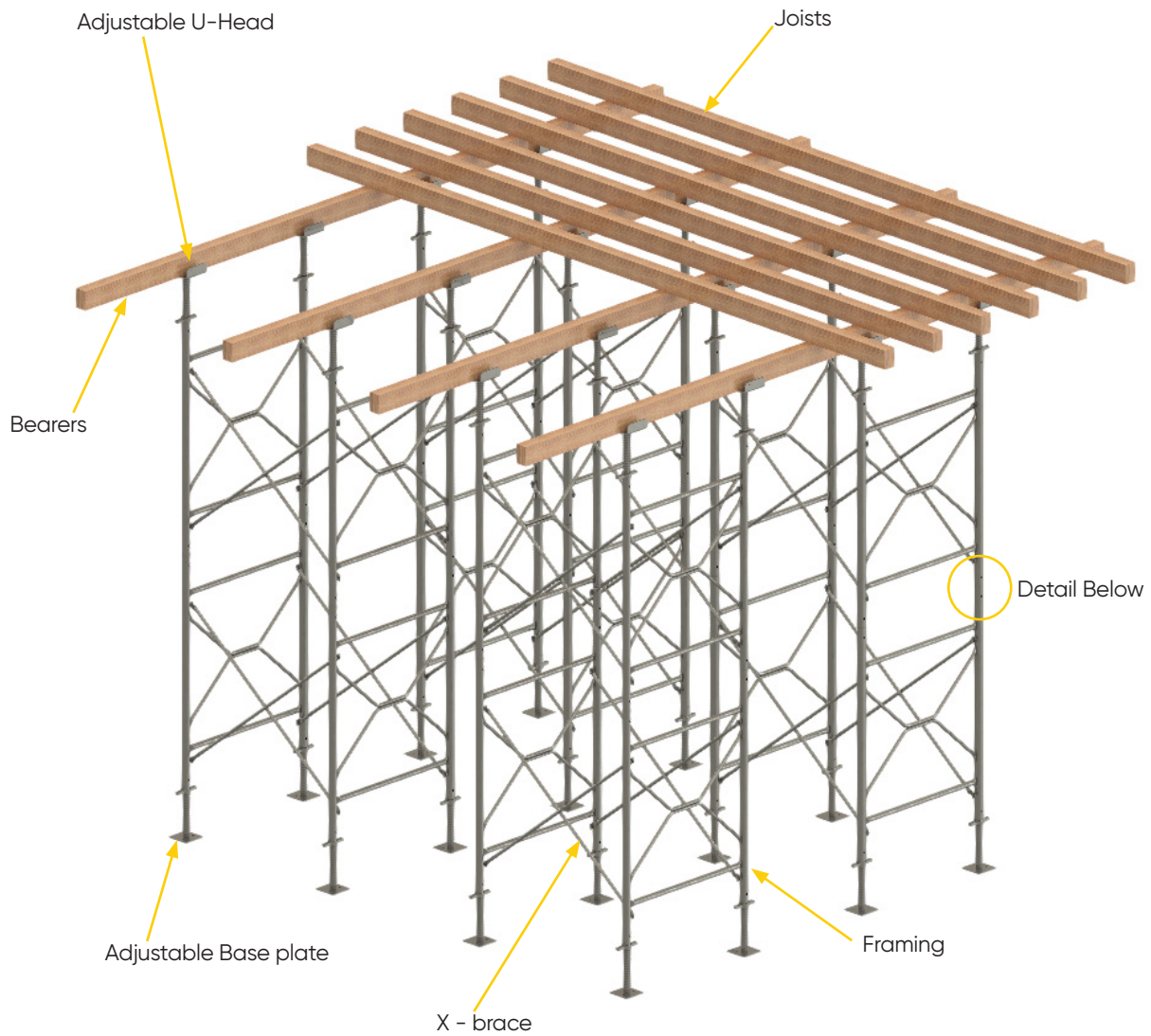

## 5. Assembly Details

### Typical Details - Perpendicular to Frame

Main bearers Perpendicular to frame - strong direction

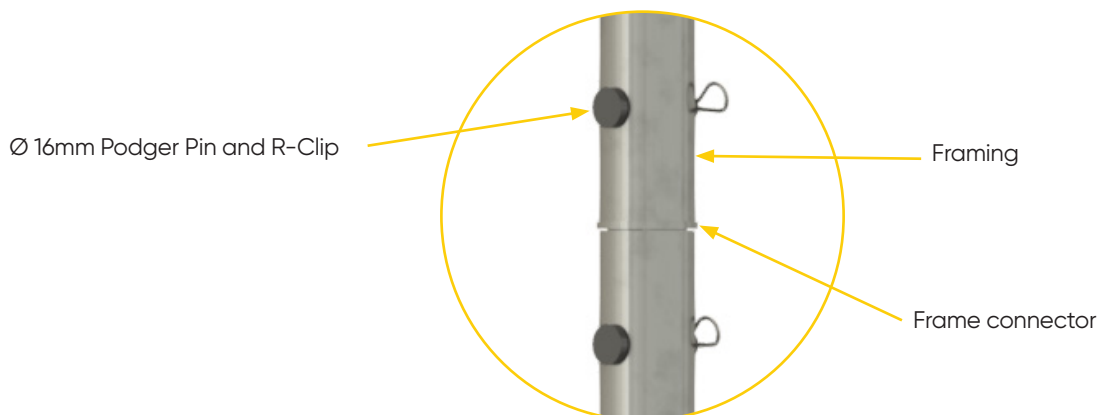
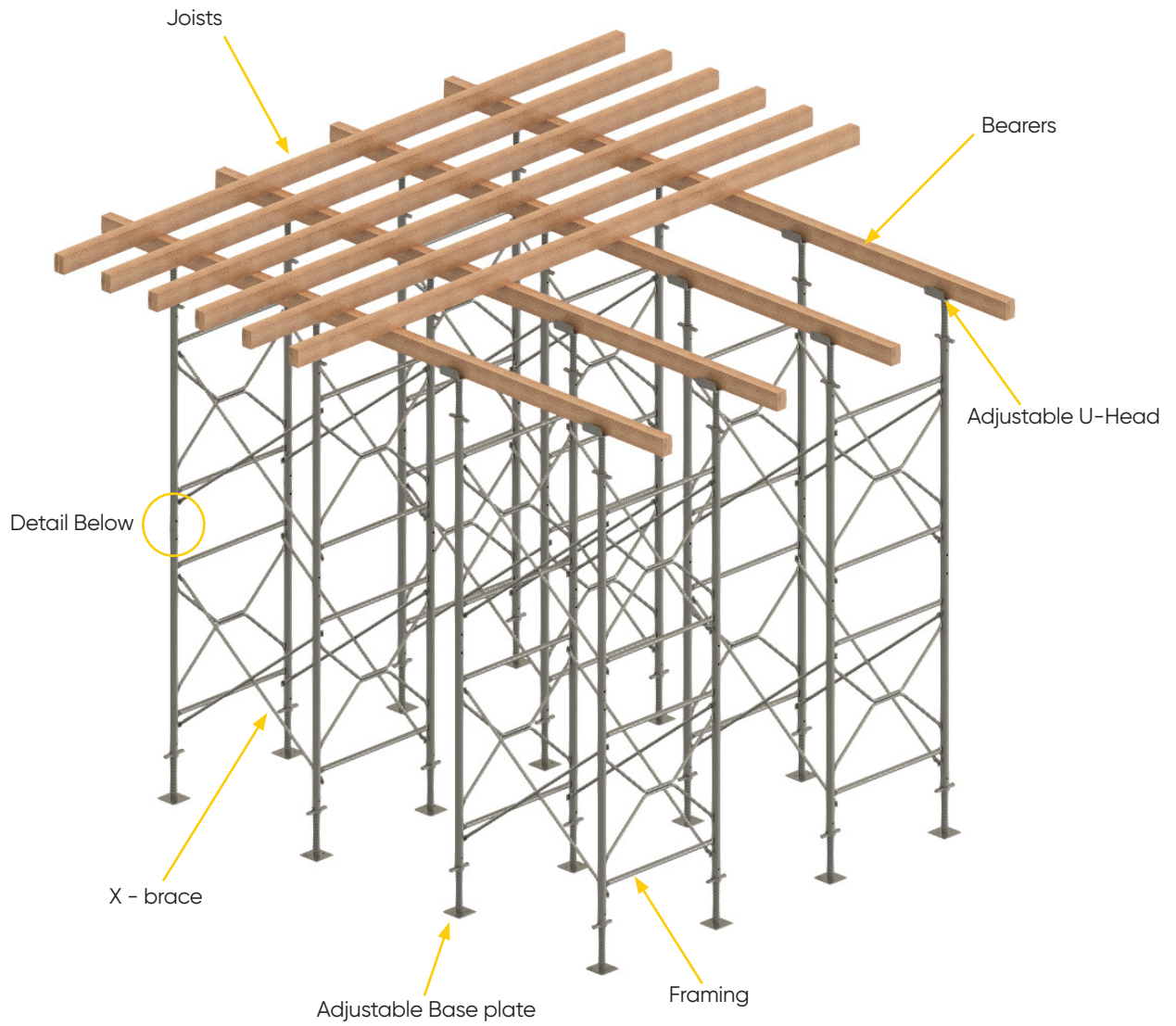

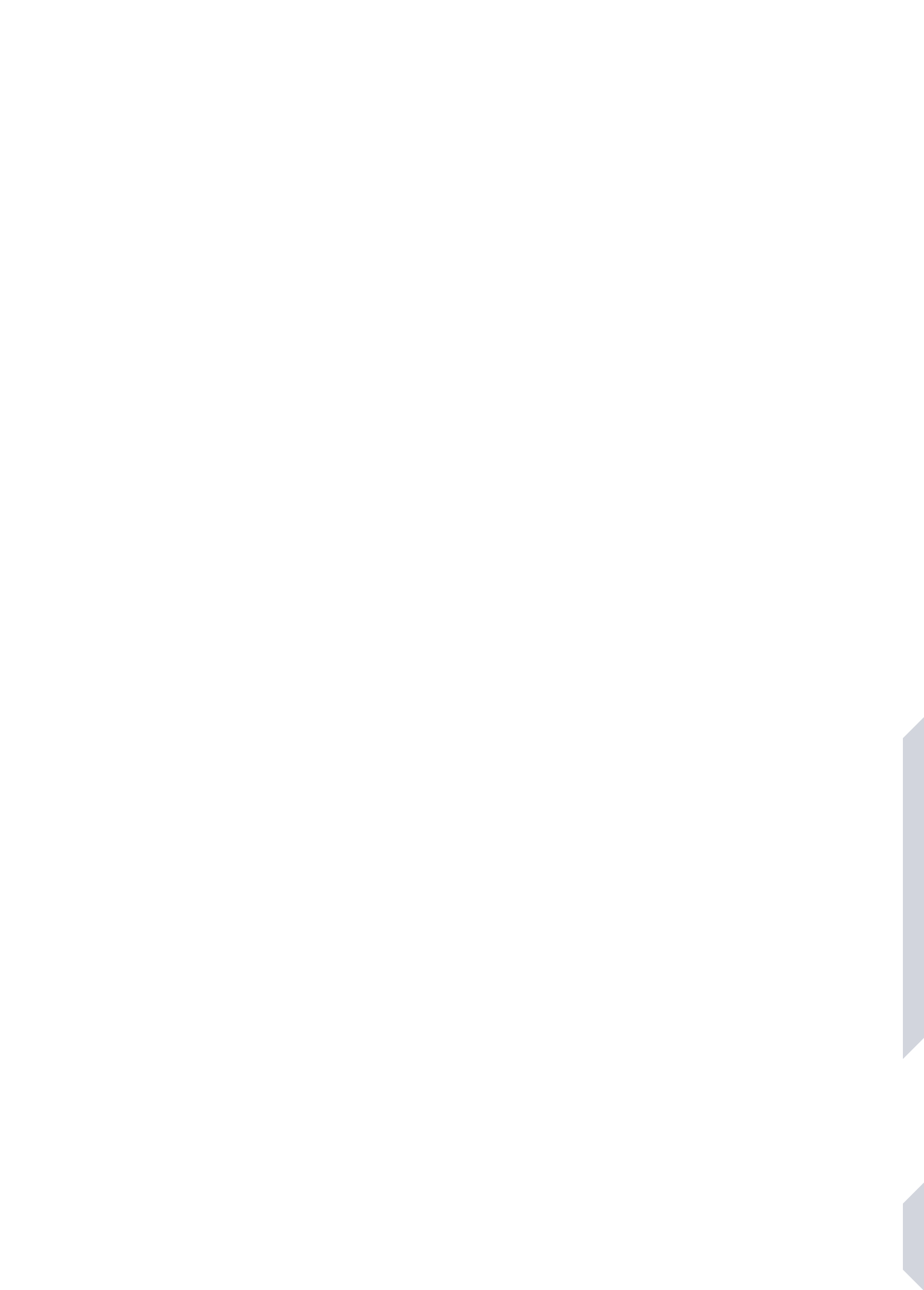

## 6. TRANSPORT & HANDLING

## 6. Transport & Handling

### Frames

The Acrow stillage is used to store a set number of items per a stillage. When a stillage is not used ensure items are bundled and placed on suitable dunnage. Items should be stored in a particular way to prevent them from falling off the stillage/bundle. The recommended method and process is:

- Stack items next to and on top to each other.
- Only pack and stack similar matching lengths per stillage. Do not mix different sizes or types in one stillage.
- Ensure every stillage load does not exceed the advised table below.
- Secure assembled items onto stillage by using at least two straps or plastic wrapped for enclosed stillages (two straps for enclosed stillage not applicable).
- Refer to Acrow Scaffold Stillage Transport and Manual Handling Document for further stacking and transport recommendations.

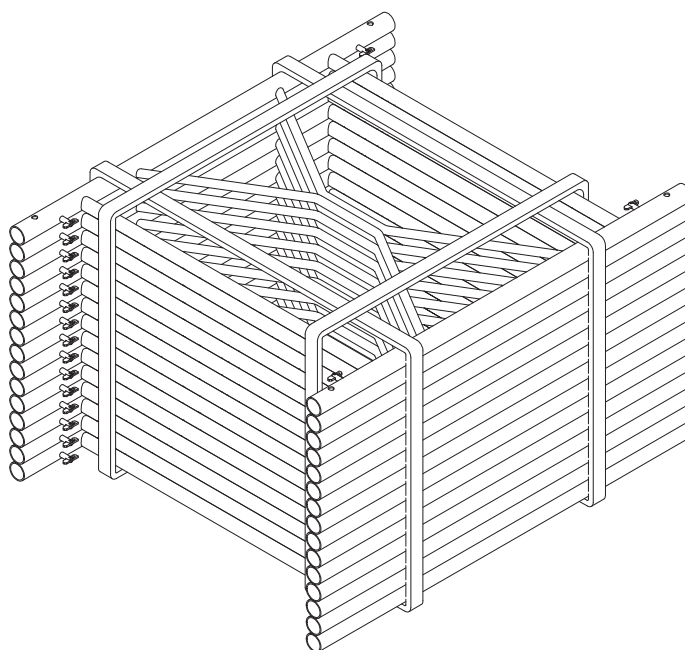

DESCRIPTION	UNIT MASS (KG)	QTY PER STILLAGE	TOTAL MASS PER STILLAGE (KG)	ACROW STILLAGE TYPE
Frame 2140 x 1219mm	32.0	25	800	Bundle
Frame 1829 x 1219mm	29.1	25	727.5	Bundle
Frame 1524 x 1219mm	26.0	25	650	Bundle
Frame 1219 x 1219mm	19.2	25	480	Bundle
Frame 914 x 1219mm	16.1	25	402.5	Bundle



## 6. Transport & Handling

### Adjustable Bases

The Acrow stillage is used to store a set number of items per a stillage. When a stillage is not used ensure items are bundled and placed on suitable dunnage. Items should be stored in a particular way to prevent them from falling off the stillage/bundle. The recommended method and process is:

- Stack items next to and on top to each other.
- Only pack and stack similar matching lengths per stillage. Do not mix different sizes or types in one stillage.
- Ensure every stillage load does not exceed the advised table below.
- Secure assembled items onto stillage by using at least two straps or plastic wrapped for enclosed stillages (two straps for enclosed stillage not applicable).
- Refer to Acrow Scaffold Stillage Transport and Manual Handling Document for further stacking and transport recommendations.

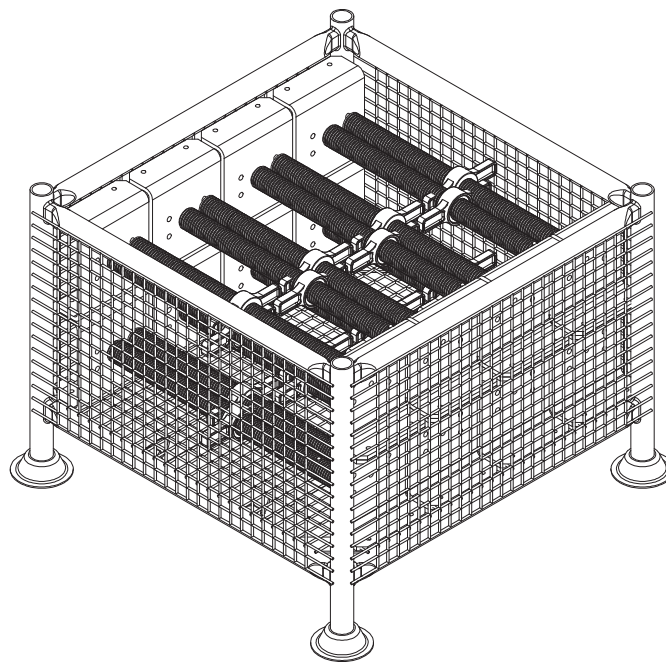

DESCRIPTION	UNIT MASS (KG)	QTY PER STILLAGE	TOTAL MASS PER STILLAGE (KG)	ACROW STILLAGE TYPE
Tubular Adjustable Bases - Base	6.3	16	100.8	MEP
Tubular Adjustable Bases - U-Head	10.3	16	164.8	MEP
Solid Adjustable Bases - Base	7.1	16	113.6	MEP
Solid Adjustable Bases - U-Head	11.1	16	177.6	MEP

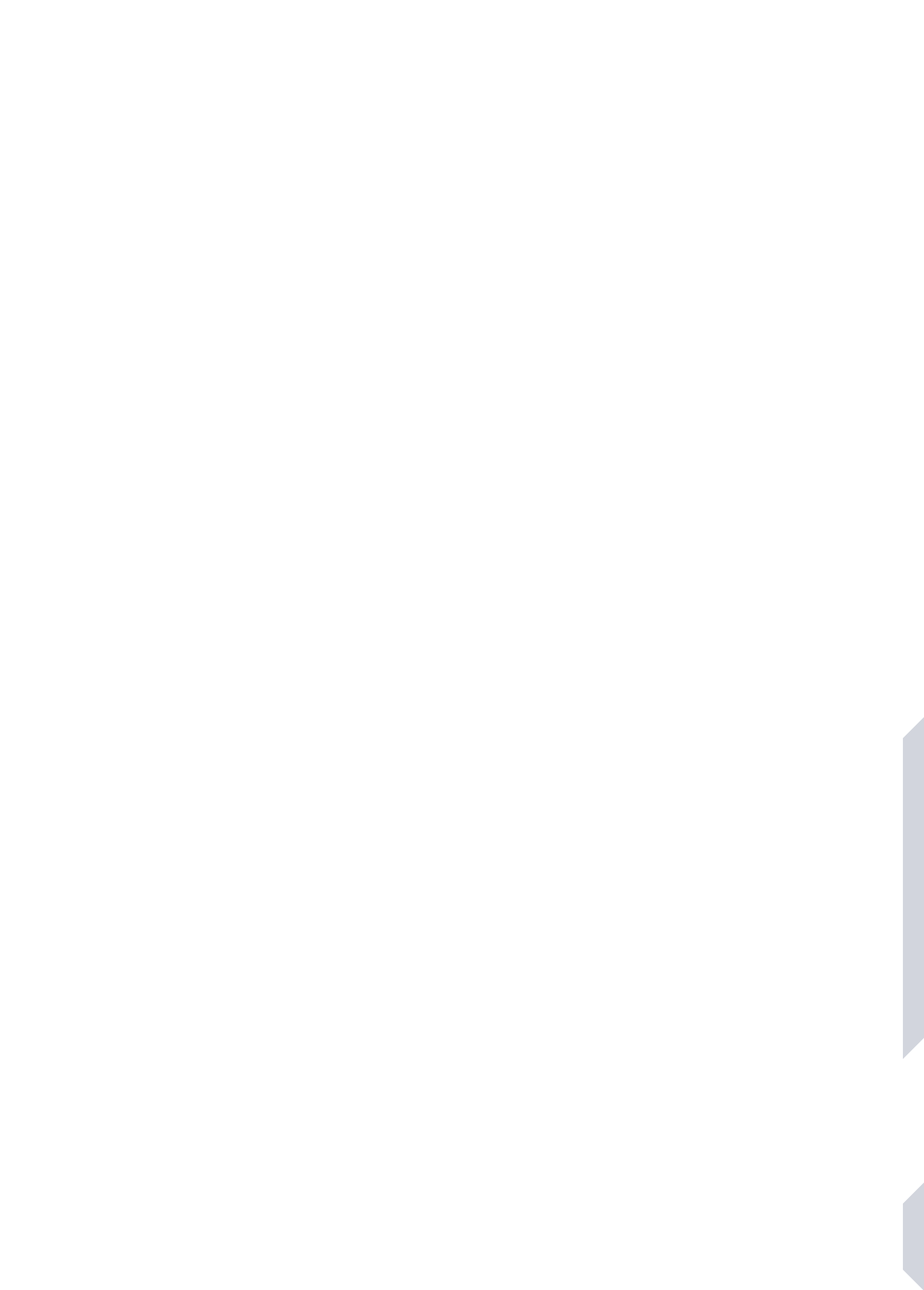

## 7. MAINTENANCE & INSPECTION

## 7. Maintenance & Inspection

### Frame Identification System - X Brace Codes

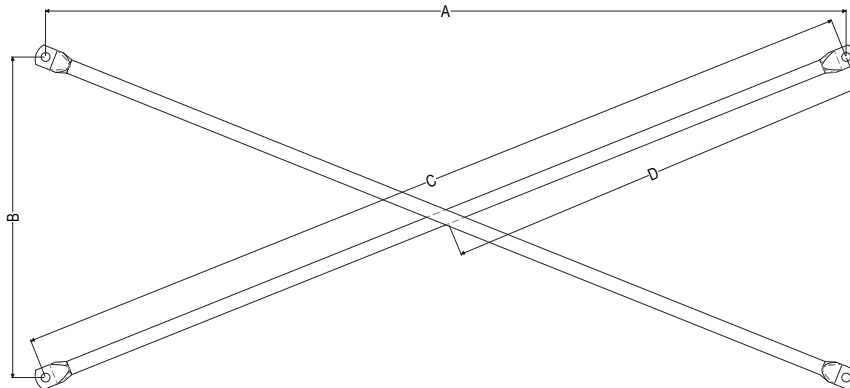

- A: Spacing of Frames
- B: Spacing of latch pins in Frame
- C: Distance between end holes
- D: Distance between end hole & centre rivet (to nearest mm)

CODE No	FRAME SIZE (ft)	BRACE SIZE			DIST. END HOLE TO END HOLE C	DIST. END HOLE TO RIVET (D)	COLOUR CODES
		A	X	B			
XB105	6 ft *	3000	x	1524	3365	1682	WHITE / RED
XB85	6 ft *	2438	x	1524	2875	1437	GOLD
XB75	6 ft *	2134	x	1524	2622	1311	DARK GREEN
XB65	6 ft *	1829	x	1524	2381	1190	DARK BLUE
XB55	6 ft *	1524	x	1524	2155	1077	RED
XB104	5/6 ft	3000	x	1220	3238	1619	WHITE / YELLOW
XB84	5/6 ft	2438	x	1220	2725	1362	LIGHT BLUE
XB74	5/6 ft	2134	x	1220	2458	1229	PINK
XB64	5/6 ft	1829	x	1220	2198	1099	WHITE
XB54	5/6 ft	1524	x	1220	1952	976	YELLOW
XB44	5/6 ft	1220	x	1220	1724	862	BLACK
XB103	4 ft	3000	x	914	3136	1568	WHITE / BLUE
XB83	4 ft	2438	x	914	2604	1302	PURPLE
XB73	4 ft	2134	x	914	2321	1190	GREY
XB63	4 ft	1829	x	914	2045	1022	LIGHT BLUE
XB53	4 ft	1524	x	914	1777	888	ORANGE
XB43	4 ft	1220	x	914	1524	762	BROWN
XB82	3 ft	2438	x	610	2513	1256	YELLOW / RED
XB72	3 ft	2134	x	610	2219	1109	YELLOW / BLACK
XB62	3 ft	1829	x	610	1928	964	YELLOW / BLUE
XB52	3 ft	1524	x	610	1642	821	YELLOW / GREEN
XB42	3 ft	1220	x	610	1363	681	YELLOW / PINK

\* = Donates frames with Brooker Latch Pin Spacing of 1524mm

## 7. Maintenance & Inspection

### Bracing

The V-Shore frame is a heavy duty support frame which is used in conjunction with X-braces, adjustable bases and U-heads to build towers to support vertical loads.

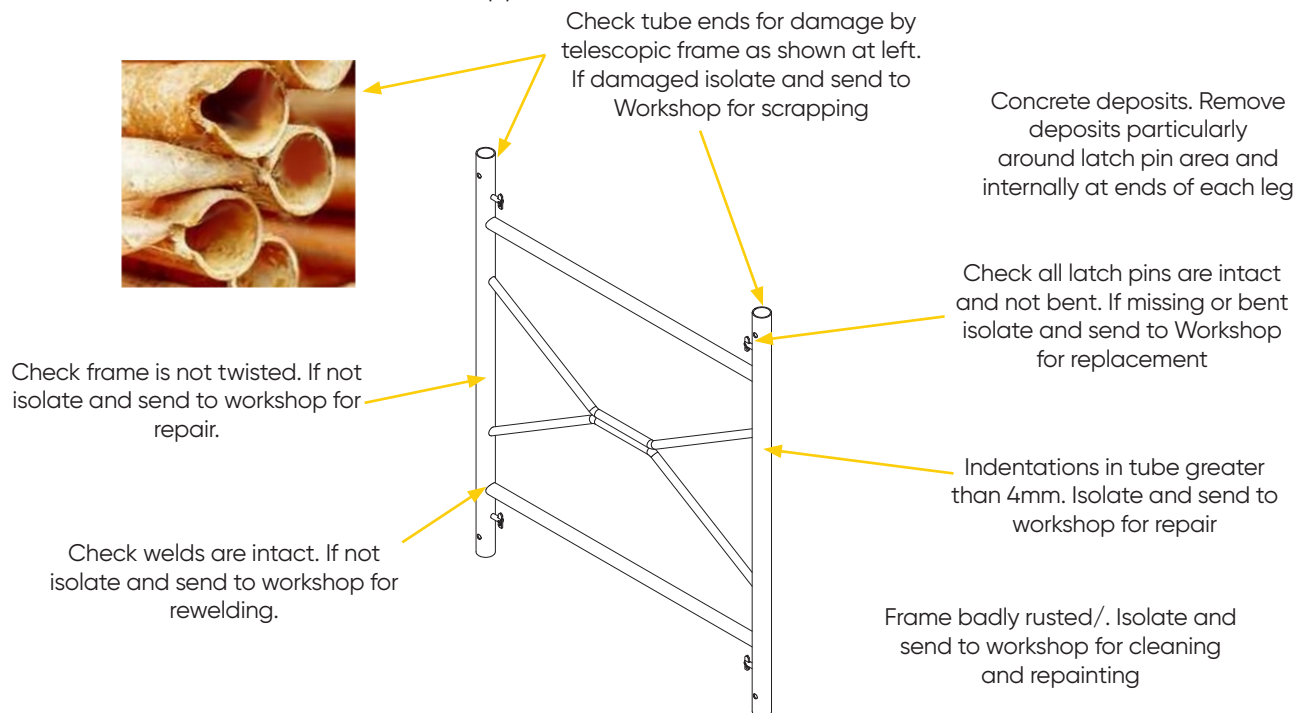

### Inspection

Generally, visual inspection checking for the possible faults listed below.

POSSIBLE FAULTS	DAMAGE LIMITS FOR REPAIR	RECOMMENDED ACTION
Frame bent or twisted	Frame must be straight and free of twist	Straighten with flypress, if unable to straighten then the unit must be scrapped* (* See WI-GE-103 for reference)
Welds cracked or broken	All welds must be intact	Grind back and reweld* (* See WI-GE-100)
Tube ends damage by Telescopic Frames	Indent of 3mm acceptable otherwise scrap	Scrap* (* See WI-GE-103)
Indentations in tube wall	Up to 4mm deep acceptable providing they aren't near the end of the tube where they would prevent penetration of adjust base etc	If indentations are greater than 4mm deep or they obstruct entry of the adjust base or U-head then the frame should be scrapped* (* See WI-GE-103)
Latch pins, damaged, bent or missing	All latch pins must be intact and soundly welded	Replace all bent and damaged pins, If weld cracked then grind back and reweld* (*See WI-GE-100)
Concrete deposits on frame	Frame must be free of concrete deposits	Remove concrete deposits particularly around latch pin area and internally at ends of each leg
Frame badly rusted	Bad rusting can result in structural weakness	If rust has not caused bad pitting, clean, treat and repaint If badly pitted then internally will also be bad so scrap

## 7. Maintenance & Inspection

### Cross Bracing

Product used to correctly space apart V-Shore and act as a load transfer member, therefore it is crucial that it be straight.

Check brace has colour coding at end. If no colour coding then brace must be colour flashed as detailed on P.g 7.1 using dimension C to determine size

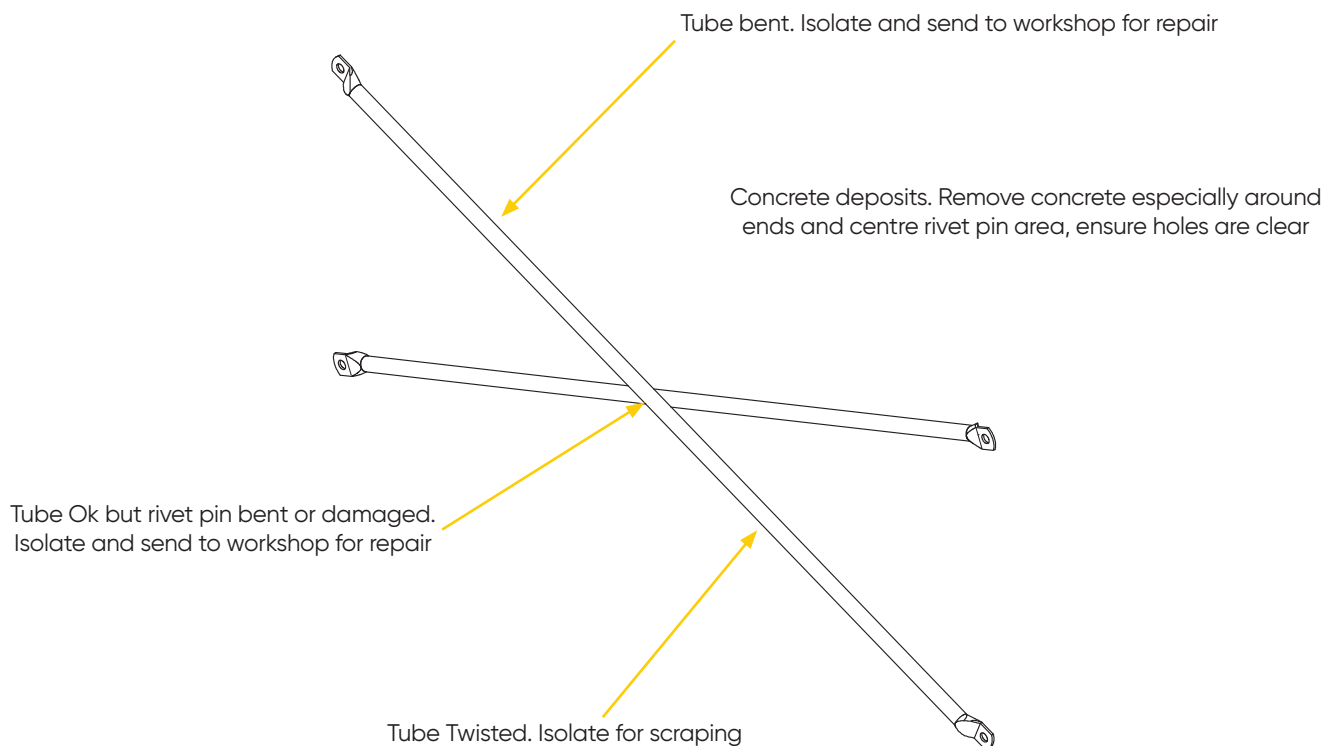

### Inspection

Generally, visual inspection checking for the possible faults listed below.

POSSIBLE FAULTS	DAMAGE LIMITS FOR REPAIR	RECOMMENDED ACTION
Tube twisted	Tube must not be twisted	Scrap* (* See WI-GE-103)
Tube bent	Tube must not be bent	Straighten with flypress, if unable to straighten then the unit must be scrapped* (* See WI-GE-103 for reference)
Rivet pin bent or damaged	Rivet pin must be intact and brace must open freely	Remove and replace pin ensuring brace can sissor freely
Colour code not on brace	Braces must be colour coded	Colour code correctly, see page 7.2 for details
Concrete deposits on brace	Braces must be free of any concrete obstruction	Clean concrete off brace making sure end holes are free and brace can sissor freely

## 7. Maintenance & Inspection

### Frame Connector

Frame connector is used to join frame together vertically it is important that the washer be square to the stem so that the frames sit neatly on top of one another.

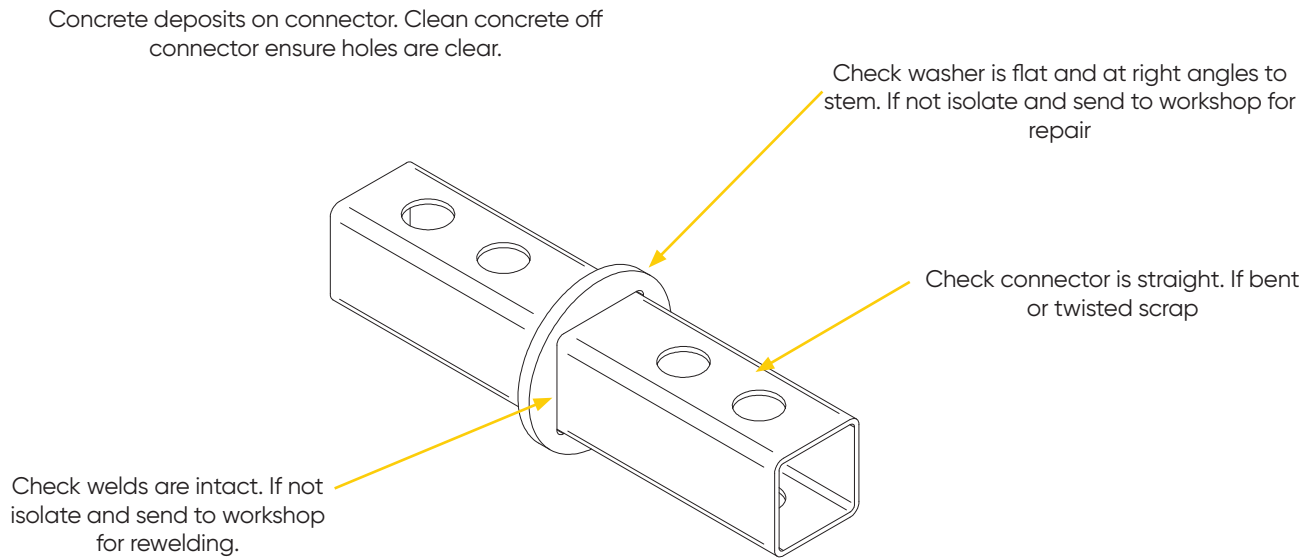

### Inspection

Generally, visual inspection checking for the possible faults listed below.

POSSIBLE FAULTS	DAMAGE LIMITS FOR REPAIR	RECOMMENDED ACTION
Connector is bent or twisted	Connector must be straight	Scrap* (* See WI-GE-103)
Welds are broken or cracked	Welds must be intact	Grind back and reweld* (* See WI-GE-100)
Washer is bent	Washer must be right angles to stem	Straighten if possible, otherwise scrap* (* See WI-GE-103)
Concrete deposits on Connector	Connector must be free of concrete	Clean concrete off connector especially around the washer area

## 7. Maintenance & Inspection

### Adjustable U-Head – Solid or Tubular

The Adjustable U-Head provides the support and adjustment for soffit formwork at the top of formwork systems. The wing nut is a cast item and incorporates a self cleaning thread. The threaded stem includes a safety stop to capture the nut and ensures that the required minimum engagement into the standard or leg is achieved. The stem must be straight and nut must be free to travel the length of the stem from the base to the stop.

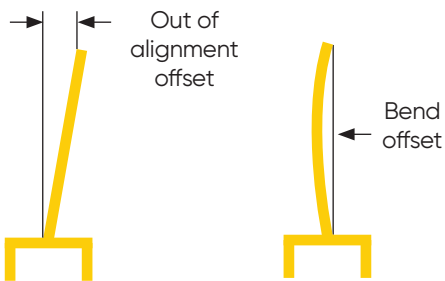
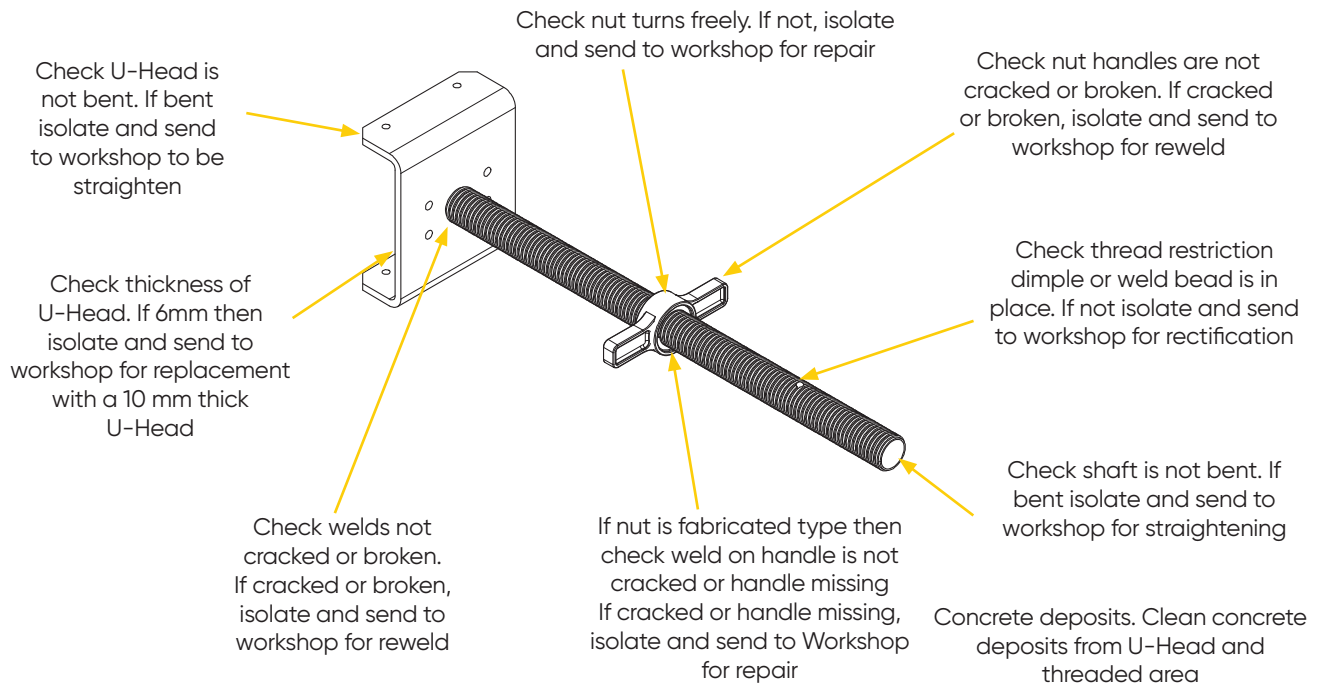

Length of Adjust U-Head	Acceptable Offset mm
760	2
596	1.5

Any bend beyond these limits must be straightened

#### TYPICAL 6mm U-HEAD

Showing bending caused by U-head being loaded by twin bearers. Testing of 6mm thick U-heads have shown that they cannot carry the maximum load our Adjustable U-heads are specified for, therefore they must be replaced with a new 10mm head obtained from AF&S Warehouse

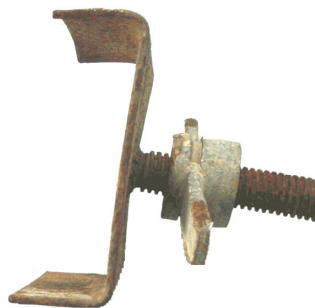

#### BENT STEMS

Slight bends in the stem can be straightened taking care not to damage the thread.

#### IMPORTANT

After any straightening, the weld must be checked for any cracking caused by the process and repaired if found to have cracked.

If stem is severely bent as shown above the unit should be scrapped. Straightening would weaken the stem at the bend point.





## 7. Maintenance & Inspection

### Adjustable U-Head – Solid or Tubular

#### Inspection

Generally, visual inspection checking for the possible faults listed below.

POSSIBLE FAULTS	DAMAGE LIMITS FOR REPAIR	RECOMMENDED ACTION
Build up of concrete or other matter	No build up permitted on tube or at connections	Remove build up with wire brush, clean threads and oil
Stem bent or damaged	Shaft must be straight and square to U-head.	Straighten or replace. After straightened recheck weld for cracks and repair if any found
Missing thread restriction dimple or weld bead	Thread restriction must be in place	Replace with weld bead at position shown on drawing.
U-Head bent, damaged or missing	U-head must be straight and true to shape	Straighten or replace. After straightened recheck weld for cracks and repair if any found
U-Head plate thickness 6mm	U-head must be 8mm plate or greater	Cut off 6mm U-head and replace with new 10mm U-Head from Factory
Cracked welds at junction of stem & U-head	Cracked welds not permitted	Grind off welds and re-weld.
Seized nut or nut with broken or cracked handles	Nut must be free to rotate, handles. Must be intact	If Seized, oil and free up ,if not possible then replace nut, If handles broken or cracked replace nut
Cracked welds on handles of fabricated nuts or handles missing	Handles must be intact with no weld cracks	Grind back weld and reweld or replace handle
Surface rust or pitting	Visual assessment.	For surface rust, Remove rust with wire brush, clean threads and lubricate as applicable. Replace component if excessively pitted.

## 7. Maintenance & Inspection

### Base Plate

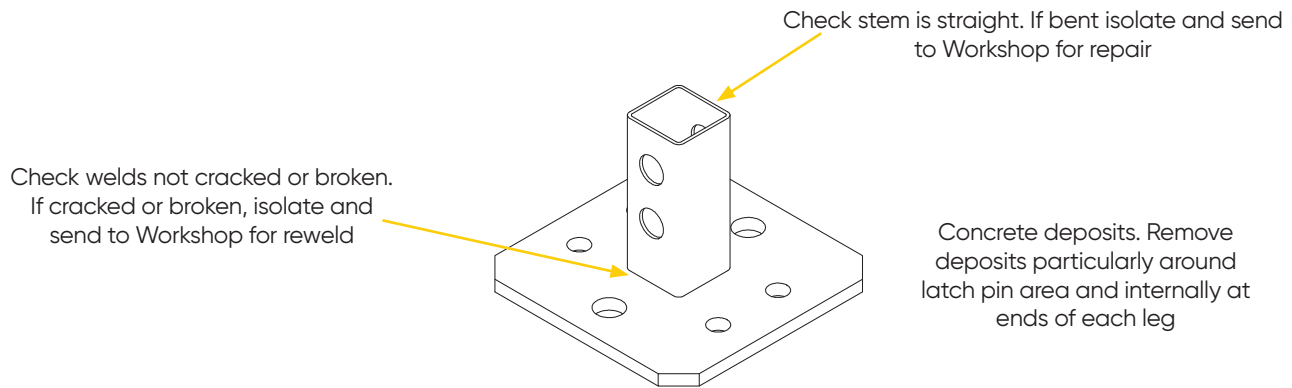

### Inspection

Generally, visual inspection checking for the possible faults listed below.

POSSIBLE FAULTS	DAMAGE LIMITS FOR REPAIR	RECOMMENDED ACTION
Build up of concrete or other matter	No build up permitted	Remove build up with wire brush
Stem bent or damaged	Stem must be straight and square to U-head	Straighten or replace
Cracked welds at base of stem	Cracked welds not permitted	Grind and re-weld.
Surface rust or pitting	Visual assessment.	For surface rust, Remove rust with wire brush. Replace component if excessively pitted.

# LOCATIONS

---

## NEW SOUTH WALES

### National Head Office

Formwork & Scaffold

2a Mavis Street

Revesby NSW 2212

P: 02 9780 6500

F: 02 9780 6499

E: [info@acrow.com.au](mailto:info@acrow.com.au)

### Screens Head Office

13-15 Vallance Street

St Marys NSW 2760

P: 02 9219 1566

## QUEENSLAND

### Formwork & Scaffold

280 Bilsen Road

Geebung QLD 4034

P: 07 3265 2266

F: 07 3865 0277

### Screens & Formwork

2 Morrison Lane

Beenleigh QLD 4207

P: 07 3807 9800

### Industrial Scaffold

22a Spanns Road

Beenleigh QLD 4207

P: 07 3442 4000

## TASMANIA

### Formwork & Scaffold

93 Lampton Avenue

Moonah TAS 7009

P: 03 6277 1212

F: 03 6277 1290

### Formwork & Scaffold

65 Boland Street

Launceston TAS 7250

P: 03 6324 8282

F: 03 6324 8250

## WESTERN AUSTRALIA

### Formwork & Scaffold

11 Jackson Street

Bassendean WA 6054

P: 08 9373 7200

F: 08 9379 3488

## SOUTH AUSTRALIA

### Formwork & Scaffold

26 Circuit Drive

Hendon SA 5014

P: 08 8359 9700

F: 08 8359 1366

## VICTORIA

### Formwork, Scaffold & Screens

159 Wellington Road

Clayton VIC 3168

P: 03 9582 2777

F: 03 9582 2790



**acrow.**

ENGINEERING & CONSTRUCTION

## Contact

Phone: 1300 138 362

[www.acrow.com.au](http://www.acrow.com.au)